

Ruijie Reyee RG-ES220GS-P-V2 Switch

Installation Guide

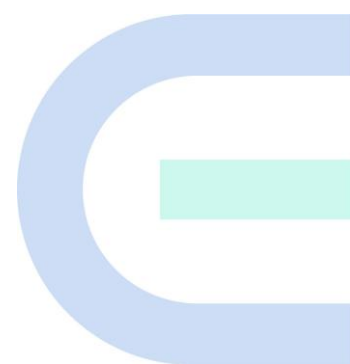

Copyright

Copyright © 2026 Ruijie Networks

All rights are reserved in this document and this statement.

Without the prior written consent of Ruijie Networks, no organization or individual is permitted to reproduce, extract, back up, modify, or distribute the content of this document in any manner or form. It is also prohibited to translate the document into other languages or use any or all parts of it for commercial purposes.

 and other Ruijie networks logos are trademarks of Ruijie Networks.

All other trademarks or registered trademarks mentioned in this document are owned by their respective owners.

Disclaimer

The products, services, or features that you purchase are subject to commercial contracts and terms. It is possible that some or all of the products, services, or features described in this document may not be available for purchase or use. Unless agreed upon otherwise in the contract, Ruijie Networks does not provide any explicit or implicit statements or warranties regarding the content of this document.

The names, links, descriptions, screenshots, and any other information regarding third-party software mentioned in this document are provided for your reference only. Ruijie Networks does not explicitly or implicitly endorse or recommend the use of any third-party software and does not make any assurances or guarantees concerning the applicability, security, or legality of such software. You should choose and use third-party software based on your business requirements and obtain proper authorization. Ruijie Networks assumes no liability for any risks or damages arising from your use of third-party software.

The content of this document is subject to constant change due to product version upgrades or other reasons. Thus, Ruijie Networks reserves the right to modify the content of the document without prior notice or prompt.

This manual serves solely as a user guide. While Ruijie Networks endeavors to ensure the accuracy and reliability of the content when compiling this manual, it does not guarantee that the content of the manual is free of errors or omissions. All information contained in this manual does not constitute any explicit or implicit warranties.

Preface

Intended Audience

This document is intended for:

- Network engineers
- Technical support and servicing engineers
- Network administrators

Technical Support

- Ruijie Reye website: <https://reyee.ruijie.com>
- Online support center: <https://reyee.ruijie.com/en-global/support>
- Case portal: <https://www.ruijie.com/support/caseportal>
- Community: <https://community.ruijie.com>
- Email support: service_rj@ruijie.com
- Live chat: <https://reyee.ruijie.com/en-global/rita>

Conventions

1. Signs

The signs used in this document are described as follows:

 **Danger**
An alert that calls attention to safety instruction that if not understood or followed can result in personal injury.

 **Warning**
An alert that calls attention to important rules and information that if not understood or followed can result in data loss or equipment damage.

 **Caution**
An alert that calls attention to essential information that if not understood or followed can result in function failure or performance degradation.

 **Note**
An alert that contains additional or supplementary information that if not understood or followed will not lead to serious consequences.

 **Specification**
An alert that contains a description of product or version support.

2. Notes

This manual provides installation steps, troubleshooting, technical specifications, and usage guidelines for cables and connectors. It is intended for users who want to understand the above and have extensive experience in network deployment and management, and assume that users are familiar with related terms and concepts.

Contents

Preface	I
1 About the RG-ES220GS-P-V2	4
1.1 Equipment Appearance	4
1.1.1 Front Panel.....	4
1.1.2 Rear Panel	5
1.1.3 LEDs	6
1.2 Technical Specifications	7
1.3 Cooling.....	6
1.4 Package Contents.....	9
2 Preparing for Installation	9
2.1 Safety Guidelines.....	9
2.1.1 General Precautions	9
2.1.2 Chassis-Lifting Guidelines	10
2.1.3 Electricity Safety	10
2.1.4 Preventing ESD Damage.....	11
2.1.5 Laser Safety	11
2.2 Site Requirements	12
2.2.1 Floor Loading	12
2.2.2 Airflow.....	12
2.2.3 Space	12
2.2.4 Temperature and Humidity.....	12
2.2.5 Cleanliness.....	12
2.2.6 Grounding	13

2.2.7 Preventing Electromagnetic Interference	14
2.2.8 Surge Protection	14
2.2.9 Installation Site.....	14
2.3 Rack Requirements	14
2.4 Tools	15
3 Installing the Switch	16
3.1 Before You Begin.....	16
3.2 Installing the Switch	16
3.2.1 Rack Mount.....	16
3.2.2 Workbench Mount.....	17
3.3 Grounding the Equipment.....	18
3.4 Connecting Cables.....	19
3.5 Bundling Cables.....	19
3.5.1 Precautions	19
3.5.2 Bundling Procedure	19
3.6 Verifying Installation.....	19
4 Commissioning.....	20
4.1 Power-on.....	20
4.2 Logging In to the Management Interface.....	20
5 Troubleshooting.....	21
5.1 General Troubleshooting Flowchart	21
5.2 Common Faults.....	21
6 Appendix.....	23
6.1 Connectors and Media.....	23

6.1.1 10/100/1000BASE-T Port	23
6.1.2 Optical Cable Connection	24
6.2 SFP Transceivers	24
6.3 Lightning Protection	27
6.3.1 Installing the AC Power Arrester (Power Strip with Surge Protection)	27
6.3.2 Installing the Ethernet Port Arrester	28
6.4 Recommended Cabling	29
6.4.1 Requirement for the Minimum Bend Radius of Cables	30
6.4.2 Precautions for Cable Bundling	30
6.5 Site Selection	33

1 Overview

1.1 About the RG-ES220GS-P-V2

The RG-ES220GS-P-V2 Ethernet switch provides 18 10/100/1000BASE-T ports, two 1GE SFP ports, one Reset button, one DIP switch, and several LEDs on the front panel, along with an AC power port and a grounding stud on the rear panel. Ports 1–16 support Power over Ethernet (PoE) Out.

Figure 1-1 RG-ES220GS-P-V2 Appearance



Note

- 1GE SFP port: Supports only 1GE SFP optical transceivers (not compatible with 100 Mbps optical cables).
- 10/100/1000BASE-T port: Supports auto-negotiation at 10 Mbps, 100 Mbps, and 1000 Mbps.

1.2 Equipment Appearance

1.2.1 Front Panel

Figure 1-2 Front Panel of the RG-ES220GS-P-V2

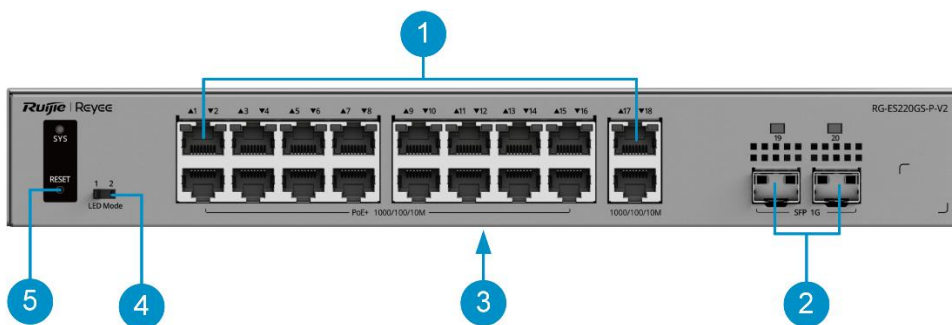

Table 1-1 Components on the Front Panel

No.	Component	Silkscreen	Description
1	RJ45 port	1000/100/10M	10/100/1000BASE-T ports, with ports 1–16 supporting PoE Out.
2	SFP port	SFP 1G	1GE SFP port, supporting 1GE SFP transceiver (hot-swappable)
3	Nameplate	-	It is located at the bottom of the switch.
4	DIP switch	LED Mode	Toggle the DIP switch to change the LED modes of ports 1–16. <ul style="list-style-type: none"> LED mode 1 (switching mode): When the DIP switch is toggled to the left, the port LEDs display the data transmission status. LED mode 2 (PoE mode): When the switch is toggled to the right, the port LEDs display the PoE status.
5	Reset button	RESET	<ul style="list-style-type: none"> Press and hold the button for less than 2 seconds. The switch is reset. Press and hold the button for 2–5 seconds. No action is performed. Press and hold the button for more than 5 seconds, and release the button until the system status LED starts blinking to restore factory settings and restart the switch.

Note

For details about LEDs on the front panel, see "LEDs."

1.2.2 Rear Panel

Figure 1-3 Rear Panel of the RG-ES220GS-P-V2



Table 1-2 Components on the Rear Panel

No.	Component	Description
1	Grounding stud	Used to connect the switch to the ground.
2	Power port	Indicates a three-pin power port used for AC power connection.
3	Power cable spring clip hole	Secures the power cord retention clip to the holes.

1.2.3 LEDs

Figure 1-4 RG-ES220GS-P-V2 LEDs

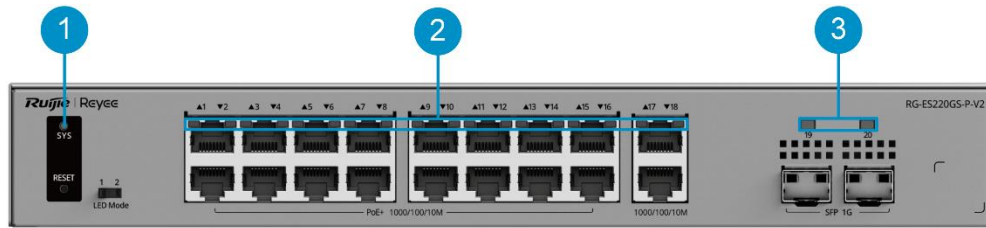

Table 1-3 LEDs

No.	Component	Silkscreen	Description
1	System status LED	SYS	<ul style="list-style-type: none"> ● Off: The switch is not powered on. ● Slow blinking green (0.5 Hz): The switch is operating normally but is not connected to Ruijie Cloud. ● Fast blinking green (10 Hz): The switch is upgrading or restarting, and is temporarily unavailable. ● Solid green: The switch is operating normally and connected to Ruijie Cloud. ● Slow blinking yellow (0.5 Hz): The PoE power is insufficient. ● Slow blinking red (0.5 Hz): A loop occurs on the switch with loop guard enabled.
2	RJ45 port LED	1–18	<p>LEDs of ports 1–16 support switching mode and PoE mode, which can be switched by toggling the DIP switch on the front of the switch.</p> <ul style="list-style-type: none"> ● Switching mode: <ul style="list-style-type: none"> ○ Off: The port is not connected. ○ Solid green: The port is operating at 1000 Mbps, 100 Mbps, or 10 Mbps, but is not receiving or sending data. ○ Blinking green: The port is operating at 1000 Mbps, 100 Mbps, or 10 Mbps, and is receiving or sending data. ● PoE mode: <ul style="list-style-type: none"> ○ Off: PoE is disabled on the port. ○ Solid green: PoE is enabled on the port. ○ Blinking green: PoE overload occurs on the port.
3	SFP port LED	19, 20	<ul style="list-style-type: none"> ● Off: The port is not connected. ● Solid green: The port is operating at 1000 Mbps, but is not receiving or sending data. ● Blinking green: The port is operating at 1000 Mbps, and is receiving or sending data.

1.3 Cooling

The RG-ES220GS-P-V2 switch has one fixed fan, which adopts air cooling and left-to-right airflow design. To ensure that the equipment works properly in the specified environment, a minimum clearance of 10 cm (3.94 in.)

must be maintained around the equipment for air circulation and ventilation. Dust the equipment every three months to avoid obstructing the air-exhaust grid of the chassis.

1.4 Technical Specifications

Warning

- This equipment is not suitable for use in locations where children are likely to be present.
- Operation of this equipment in a residential environment could cause radio interference.

Table 1-4 Technical Specifications

Parameter Type	Parameter Name	RG-ES220GS-P-V2
System Specifications	Forwarding rate	29.76 Mpps
	Switching capacity	40 Gbps(bit/s)
	Flash memory	8 MB
Port Specifications	Total number of optical ports	2
	Total number of RJ45 ports	18
	Number of 10/100/1000BASE-T ports	18
	Number of 1GE SFP ports	2
	Reset button	1
	LEDs	1 x system status LED 18 x Ethernet port LEDs 2 x SFP port LEDs
DIP switch	LED mode switch toggled to left (Mode 1): The port LED status indicates the status of traffic transmission. Solid green means that the port is link up, while blinking green means that the port is transmitting and receiving data. LED mode switch toggled to right (Mode 2): The port LED status indicates the PoE status. Solid green means that the port is supplying power, while blinking green means that the port is in power overload state.	
Power Supply and Consumption	Power supply	Fixed power supply
	Power input	220 V AC power supply: <ul style="list-style-type: none"> ● Rated input voltage: 100 V AC to 240 V AC, 50 Hz to 60 Hz ● Maximum input voltage: 90 V AC to 264 V AC, 47 Hz to 63 Hz ● Rated input current: 6 A
	Maximum power consumption	20W (with no PoE load) 287W (with full PoE load)
	Number of PoE Out ports	16

Parameter Type	Parameter Name	RG-ES220GS-P-V2
	Number of PoE/PoE+ Out ports	16
	PoE Out standard	PoE/PoE+ (IEEE 802.3af/at)
	PoE power pins	1–2 (+), 3–6 (-)
	PoE budget per port	30 W
	PoE budget	250 W
Dimensions and Weight	Product dimensions (W x D x H)	300 mm x 223 mm x 43.6 mm (11.81 in. x 8.78 in. x 1.72 in.)
	Weight	2.06 kg (4.54 lbs) (without packaging materials)
	Shipping weight	2.95Kg (6.50 lbs)
	Casing	Metal
Interface	EEE	Yes
Environment and Reliability	Mounting options	Rack/Desk
	Hot swapping of cables	Hot swapping supported by the service port and power connector
	Fan	1 x fixed fan
	Cooling	Air cooling, left-to-right airflow
	MTBF	200,000 hours
	ESD protection	Air discharge: 8 kV Contact discharge: 6 kV
	Surge protection	Service port: ±6 kV for common mode Power connector: ±6 kV for common mode and ±6 kV for differential mode
	Operating temperature	0°C to 40°C (32°F to 104°F)
	Storage temperature	-40°C to +70°C (-40°F to +158°F)
	Operating humidity	10% RH to 90% RH (non-condensing)
	Storage humidity	5% RH to 95% RH (non-condensing)
	Altitude	-500 m to +5,000 m (-1,640.42 ft. to +16,404.20 ft.)
Certification and Regulatory Compliance	EMC	EN 55032 EN 61000-3-2 EN 61000-3-3 EN 55035 EN 300 386
	Safety compliance	EN 62368-1 IEC 62368-1
	Certification	CE,CB

2 Preparing for Installation

2.1 Package Contents

Table 2-1 Package Contents

No.	Item	Quantity
1	RG-ES220GS-P-V2 switch	1
2	Rubber pad	4
3	<i>User Manual</i>	1
4	<i>Warranty Card</i>	1
5	M3 x 6 mm cross recessed countersunk head screw	6
6	Rack-mount bracket	2
7	Power cord	1
8	Power cord retention clip	1

Note

The package contents are subject to the purchase contract, and actual delivery may vary. Please check the items carefully against the package contents or purchase contract. If you have any questions, please contact the distributor.

2.2 Safety Guidelines

Note

- To avoid personal injury or equipment damage, review the safety guidelines in this chapter before you begin the installation.
- The following safety guidelines may not include all the potentially hazardous situations.

2.2.1 General Precautions

- Install the equipment in a standard 19-inch rack and ensure that the rack and power distribution system are properly grounded.
- Never operate the equipment in a wet environment, and avoid any liquids inside it. Keep the chassis clean and dust-free.
- Keep the equipment away from heat sources.
- Keep the equipment away from walk areas.
- During installation and maintenance, do not wear loose clothing or ornament that may get caught in the

chassis.

- Keep tools and accessories away from walk areas.

2.2.2 Chassis-Lifting Guidelines

- Avoid moving the equipment frequently.
- Turn off all power supplies and disconnect all cables before lifting or moving the equipment.
- Two or more people are required to lift the chassis. Keep balance and prevent personal injuries when lifting or moving the equipment.

2.2.3 Electricity Safety

Warning

- Any deviation from standard or improper electrical operations can result in accidents such as fires or electric shocks, potentially causing severe or even fatal harm to both individuals and equipment.
 - Direct or indirect touch through a wet object on high-voltage and mains supply can bring a fatal danger.
-
- Always observe the local regulations and standards. Only qualified personnel should be allowed to operate the equipment.
 - Carefully check the work area for potential hazards, including ungrounded power system, absent safety grounds, and damp floors.
 - Locate the emergency power-off switch in the room before installation. In the case of an accident, cut off the power supply immediately.
 - Never assume that power is connected to or disconnected from a circuit. Always check.
 - Select the right leakage protector (also called "leakage current switch" or "leakage current breaker") for the power supply system. This equipment automatically disconnects the power supply in the event of leakage and the risk of electric shock. A leakage protector should meet the following requirements:
 - The rated leakage action current of each leakage protector must be at least twice the total maximum leakage current of all connected power supplies.
Example:
If a system has 16 identical power supplies, each with a maximum leakage current of 3.5 mA:
Total leakage current = 16 x 3.5 mA = 56 mA
For a 30 mA leakage protector:
Maximum number of power supplies per protector = 30 mA/2/3.5 mA ≈ 4
Therefore, only four power supplies can be connected to one 30 mA leakage protector.
To support 16 power supplies, at least four 30 mA leakage protectors are required.
Always ensure:
Rated leakage operating current/2 > Total maximum leakage current of connected power supplies
 - The rated leakage non-action current of a leakage protector should be 50% of the leakage action current. If the non-action current value is too small, the high sensitivity level can cause the circuit to break, leading to power cutoff and service interruption, even if the leakage current value is normal.
-

For example, if a leakage protector has a rated leakage action current of 30 mA, the rated leakage non-action current should be 15 mA. The leakage protector will not activate unless the leakage current exceeds 15 mA.

⚠ Caution

- To ensure personal safety, each leakage protector in the system must have a rated leakage action current equal to or below 30 mA, which is the recognized safety threshold for human body current. If the total leakage current of the system exceeds twice the 30 mA limit, the system must be equipped with two or more leakage protectors to maintain safety.
 - The leakage current values vary with equipment. For the leakage current value of each equipment model, see "Technical Specifications."
-

2.2.4 Preventing ESD Damage

- Ensure that the chassis is connected to earth ground.
- Keep the site as dust free as possible.
- Maintain appropriate humidity conditions.
- Before installing any pluggable modules, wear an anti-ESD wrist strap and make sure that it is properly grounded.
- Avoid contact between the printed circuit boards and clothing. The anti-ESD wrist strap only protects the printed circuit boards from ESD voltages on the body. ESD voltages on clothing can still cause damage.

2.2.5 Laser Safety

The equipment supports various types of optical transceivers, which are Class 1 laser products.

Precautions:

- When an optical transceiver is working, ensure that its port is connected to an optical cable or covered by a dust cap to keep out dust and prevent it from burning your eyes.
- Do not stare into an optical port.

Figure 2-1 Laser Product ID

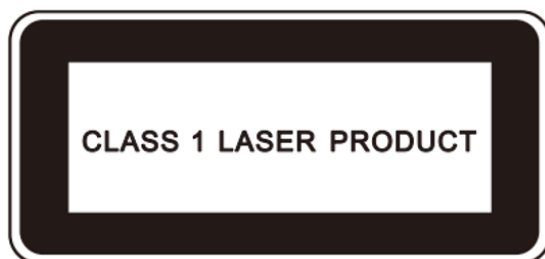

⚠ Caution

Do not approach or stare into an optical port under any circumstances. This may cause permanent damage to your eyes.

2.3 Site Requirements

The equipment must be installed indoors for normal operation and prolonged service life.

The installation site must meet the following requirements.

2.3.1 Floor Loading

Assess the combined weight of the equipment and its accessories, such as rack, chassis, and power modules, and verify that the floor under the rack can bear the weight.

2.3.2 Airflow

The equipment adopts natural cooling. Reserve a sufficient clearance around the equipment to ensure proper ventilation.

2.3.3 Space

You are advised to have a pathway of at least 0.8 m (2.62 ft.) wide in the equipment room. This space ensures that you can move the chassis and swap the modules easily.

Do not install the equipment against a wall. Instead, maintain a minimum clearance of 10 cm (3.94 in.) around the equipment for heat dissipation and equipment maintenance.

2.3.4 Temperature and Humidity

To ensure the normal operation and a prolonged service life of the equipment, maintain an appropriate temperature and humidity in the installation environment.

Prolonged exposure to inappropriate temperature and humidity conditions can cause damage to the equipment.

- In an environment with high relative humidity, insulating materials are prone to poor insulation or even electricity leakage.
- In an environment with low relative humidity, insulating gaskets may shrink, resulting in screw loosening.
- In a dry environment, static electricity is more likely to occur, posing a risk to the internal circuits of equipment.
- A high temperature can accelerate the aging process of insulation materials, greatly reducing the availability of the equipment and severely affecting its service life.

2.3.5 Cleanliness

Dust poses a significant hazard to the equipment. Dust on the enclosure causes electrostatic adhesion, leading to poor contact of the metallic joints. Electrostatic adhesion is more likely to occur in an indoor environment with relatively low humidity, not only affecting the service life of the equipment, but also causing communication faults.

The following table lists the requirements for dust concentration and particle size in the equipment room.

Table 2-2 Requirements for Dust

Particle Diameter	Unit	Concentration
≥ 0.5 μm	Particles/m ³	≤ 3.5 × 10 ⁶
≥ 5 μm	Particles/m ³	≤ 3.5 × 10 ⁶

Apart from dust, there are also requirements on the salt, acid, and sulfide in the air of the equipment room. These harmful substances will accelerate metal corrosion and component aging. Therefore, the equipment room should be properly protected against harmful gases, such as sulfur dioxide, hydrogen sulfide, nitrogen dioxide, and chlorine gas. The following table lists the limits on harmful gases.

Table 2-3 Requirements for Gases

Gas	Average (mg/m ³)	Maximum (mg/m ³)
Sulfur dioxide (SO ₂)	0.3	1.0
Hydrogen sulfide (H ₂ S)	0.1	0.5
Nitrogen dioxide (NO ₂)	0.5	1.0
Chlorine gas (Cl ₂)	0.1	0.3

 **Note**

Average refers to the average value of harmful gases measured in a week. **Maximum** refers to the upper limit of harmful gases measured in a week for up to 30 minutes every day.

2.3.6 Grounding

A proper grounding system is crucial for ensuring stable and reliable operation, as well as preventing lightning strikes and interference. Carefully check the grounding conditions at the installation site according to the grounding requirements, and complete grounding properly based on the site situation.

- Safety Grounding

Ensure that the rack and power distribution system are securely grounded if the equipment uses the AC power supply. Otherwise, electric shocks may occur when the insulation resistance between the power module and the chassis decreases.

 **Caution**

- The building should provide a protective ground connection to ensure that the equipment is connected to a protective ground.
- Verify that the AC socket is reliably connected to the protective grounding system of the building. If not, a protective grounding wire should be used to connect the protective grounding lug of the AC socket to the protective grounding system of the building.

- Lightning Grounding

The lightning protection system is an independent system composed of a lightning rod, a downlead conductor, and a connector connected to the grounding system. The grounding system is typically used for power reference grounding and safety grounding of the rack. Lightning grounding is required only for facilities, and is not required for the equipment.

- EMC Grounding

Electromagnetic compatibility (EMC) grounding includes shielded grounding, filter grounding, noise and interference suppression, and level reference.

2.3.7 Preventing Electromagnetic Interference

- Take interference prevention measures for the power supply system.
- Keep the equipment away from the grounding system or lightning protection grounding system of the power facility.
- Keep the equipment far away from high-frequency current equipment such as high-power radio transmitting stations and radar launchers.
- Take electromagnetic shielding measures when necessary.

2.3.8 Surge Protection

Although the equipment can guard against lightning strikes, strong lightning strikes may still damage the equipment. Take the following surge protection measures:

- Ensure that the grounding wire of the rack is in good contact with the ground.
- Ensure that the neutral point of the AC power socket is in good contact with the ground.
- Install a power arrester in front of the power input end to enhance surge protection for the power supply.

2.3.9 Installation Site

Regardless of whether the equipment is installed in a rack or on a workbench, ensure that the following conditions are met:

- Maintain a proper clearance around the air inlets and outlets for heat dissipation.
- Install the equipment in a standard 19-inch rack. Alternatively, place the equipment on a clean workbench. The installation of air conditioners is recommended in hot areas.
- The installation site has a good cooling and ventilation system.
- The installation site is sturdy enough to support the weight of the chassis and its accessories.
- The installation site is properly grounded.

2.4 Rack Requirements

If you plan to install the equipment in a rack, ensure that the rack meets the following conditions.

- (1) Use a four-post 19-inch rack.
- (2) The left and right square-hole rack posts are 465 mm (18.31 in.) apart.

Figure 2-2 19-Inch Rack

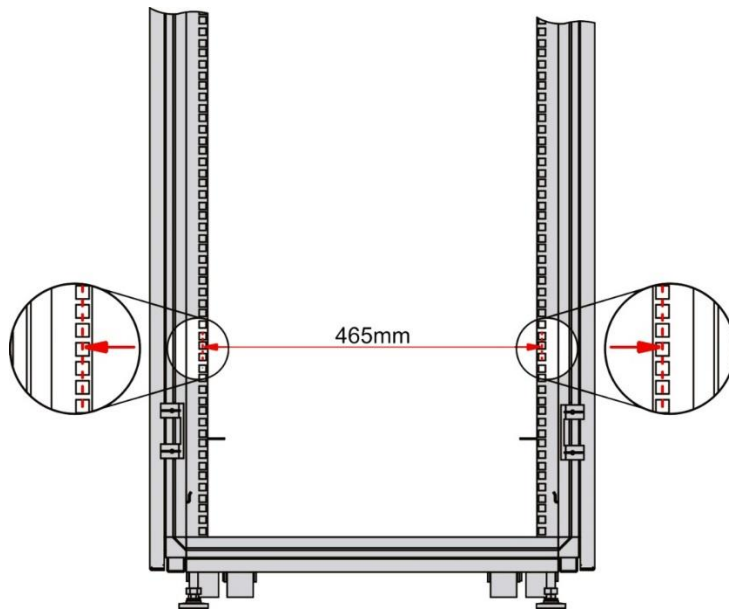

- (3) The square-hole rack post is at least 180 mm (7.09 in.) from the front door, and the front door is at most 25 mm (0.98 in.) thick. This ensures an available clearance of at least 155 mm (6.10 in.). The rack depth (distance between front and rear doors) is at least 1000 mm (39.37 in.).
- (4) The guide rails or tray can bear the weight of the equipment and its accessories.
- (5) The rack has a reliable grounding lug for the chassis to connect to earth ground.
- (6) The rack has a reliable ventilation system. The open area of front and rear doors is greater than 50%.

2.5 Tools

Table 2-4 Tools

Common Tools	Phillips screwdriver, cables, cage nuts, diagonal pliers, cable ties, and grounding wires
Dedicated Tools	Anti-ESD gloves, wire stripper, crimping pliers, RJ45 crimping pliers, and wire cutter
Meter	Multimeter

Note

The equipment is delivered without a toolkit. Prepare the preceding tools by yourself.

3 Installing the Switch

Caution

Before installing the equipment, ensure that guidelines and requirements in Chapter 2 have been met.

3.1 Before You Begin

- The installation site provides sufficient space for heat dissipation.
- The installation site meets the temperature and humidity requirements.
- The power supply is available at the installation site, and its current meets the requirements.
- The Ethernet cables have been deployed at the installation site.
- Locate the emergency power-off switch in the room before installation. In the case of an accident, cut off the power supply immediately.

3.2 Installing the Switch

3.2.1 Rack Mount

Install the RG-ES220GS-P-V2 switch in a standard 19-inch rack. The installation steps are as follows:

- (1) Take out the M3 x 6 mm cross recessed countersunk head screws delivered with the switch. Attach a rack-mount bracket to each side of the switch and secure it with three screws.

Figure 3-1 Securing Rack-Mount Brackets

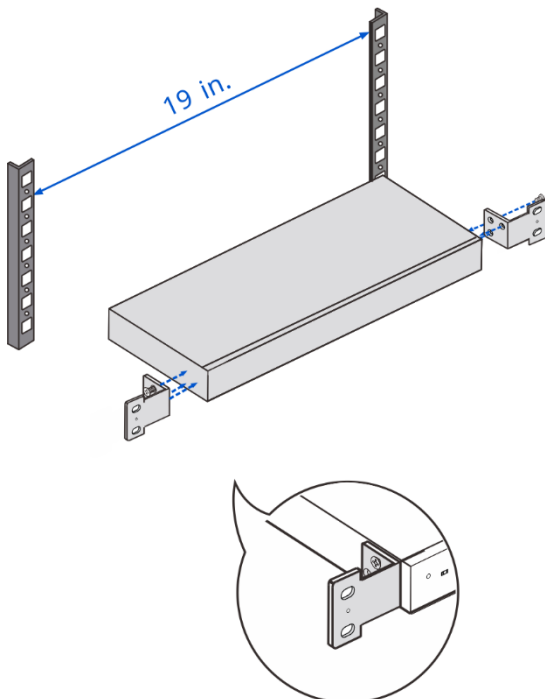

- (2) Horizontally position the switch at the desired location in the rack, and secure the other end of the rack-mount brackets to front square holes of the rack using four M6 screws and four cage nuts.

Figure 3-2 Installing the Switch in a Rack

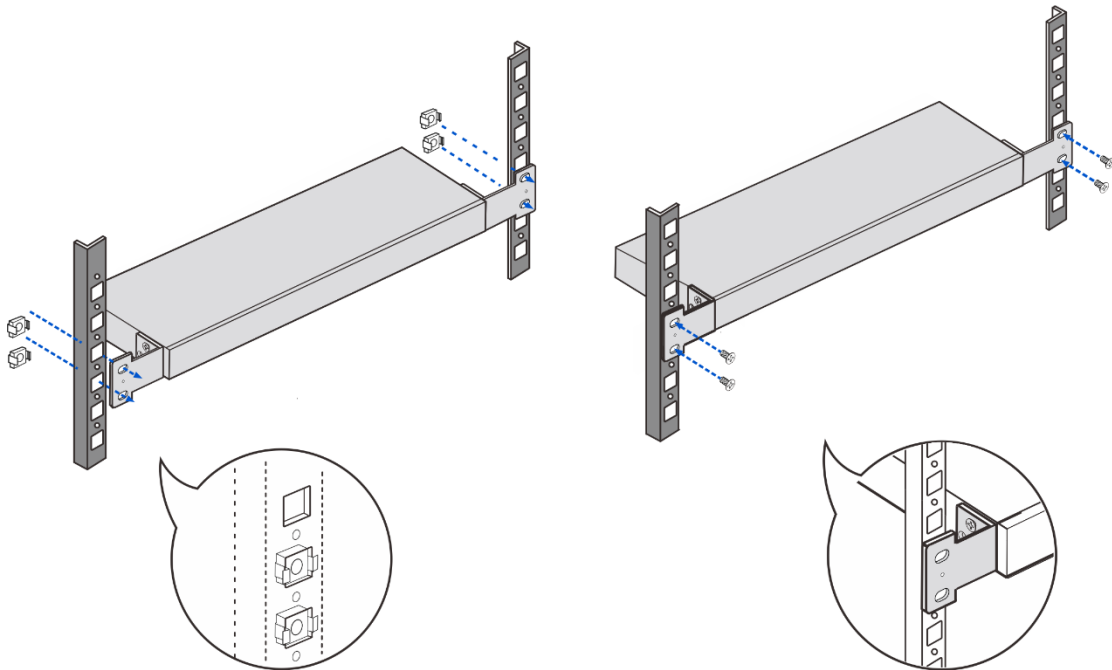

3.2.2 Workbench Mount

In most cases, users do not have a standard rack, and equipment can be placed on a clean workbench. The installation process is as follows:

- (1) Attach the four rubber pads in the package to the dents at the four corners on the bottom of the switch.

Figure 3-3 Attaching the Rubber Pads

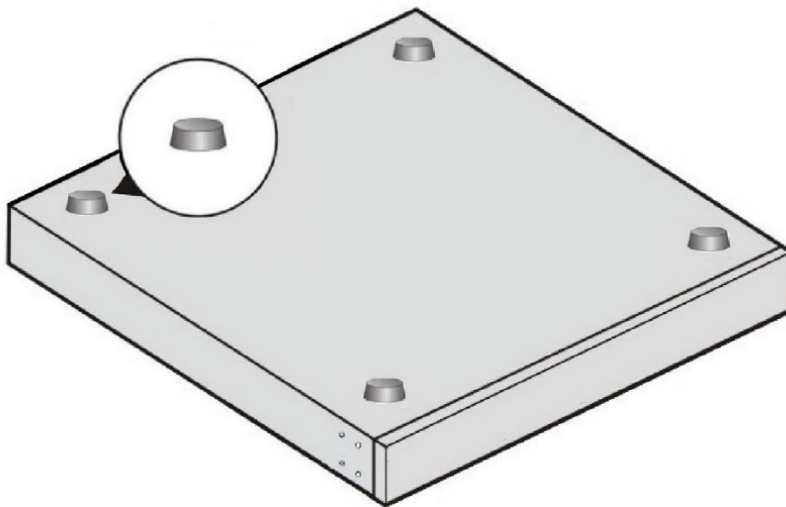

- (2) Place the equipment on a workbench.

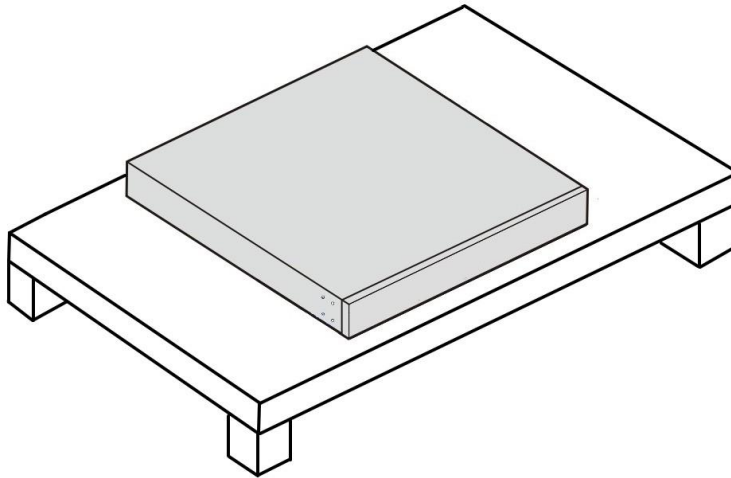
Figure 3-4 Placing the Equipment on a Workbench

3.3 Grounding the Equipment

Note

- If the equipment is installed on a workbench, connect the grounding wire to the nearest grounding bar or grounding point based on the onsite situation.
 - The grounding wire is not delivered with the equipment and needs to be purchased by the customer.
-

The equipment has a grounding stud on the rear panel. You are advised to connect the system grounding wire to it before using the equipment.

- (1) Purchase a grounding wire and connect one end to the grounding stud at the rear of the equipment.
- (2) Connect the other end to the grounding lug of the rack. Ensure the grounding lug of the rack has been connected to the grounding bar.

Caution

- To avoid personal injury and equipment damage, connect the switch to earth ground properly. The grounding resistance between the chassis and the ground should be less than 1 ohm.
 - The O&M personnel should verify whether the AC socket is reliably connected to the protective ground of the building. If not, the O&M personnel should use a protective grounding wire to connect the protective grounding lug of the AC socket to the protective ground of the building.
 - The power socket should be installed near the equipment and easily accessible.
 - During the equipment installation, connect the grounding wire first and disconnect it last.
 - The sectional area of a grounding wire should be determined according to the possible maximum current. Grounding wires with good conductors should be used.
 - Do not use bare wires.
-

3.4 Connecting Cables

Caution

- All cables must be routed indoors. Take surge protection measures if they need to be routed outdoors.
 - When connecting an optical cable, connect the transmit (TX) port on the local equipment to the receive (RX) port on the peer equipment, and vice versa.
-

After the switch is installed, connect the switch to other equipment according to the following steps:

- (1) Connect the power cord delivered with the switch to the power strip.
- (2) Connect the RJ45 connector of a twisted pair to an Ethernet port on the switch, and the other end to downlink equipment.
- (3) Insert an optical transceiver into the optical port first according to the panel identification. Then connect a single-mode fiber (SMF) or multimode fiber (MMF) to the corresponding optical transceiver, during which the transmitting and receiving ends of the optical cable should be distinguished.

3.5 Bundling Cables

3.5.1 Precautions

- Bundle the power cord and other cables in an esthetically pleasing way.
- Make sure that the optical cables at the connectors have natural bends or bends of large radius.
- Do not bind optical cables and twisted pairs too tightly, as this may press the cables and affect their service life and transmission performance.

3.5.2 Bundling Procedure

- (1) Bind the drooping part of the optical cables and twisted pairs, and lead them to both sides of the chassis for convenience.
- (2) On both sides of the chassis, fasten the optical cables and twisted pairs to the cable management ring or cabling chute.
- (3) Bind the power cord closely along the bottom of the chassis, in a straight line wherever possible.

3.6 Verifying Installation

Caution

Please turn off the power to avoid personal injury and damage to components caused by incorrect connection.

- Verify that the grounding wire is connected.
- Verify that the cables including power cords are properly connected.
- Verify that cables connected to ports are routed indoors.
- Verify that the surge protection socket and Ethernet port arrester are installed, if outdoor cabling exists.
- Verify that there is a minimum clearance of 10 cm (3.94 in.) around the switch.

4 Commissioning

4.1 Power-on

- (1) Checklist Before Power-on
 - The switch is properly grounded.
 - The power cord is properly connected.
 - The power supply voltage meets the requirement of the switch.
- (2) Checklist After Power-on (Recommended)
 - The switch LEDs are in the normal state.
 - Service ports can forward data properly.

4.2 Logging In to the Management Interface

- (1) Connect a PC to an Ethernet port on the switch through an Ethernet cable.
- (2) Set the IP address of the PC to 10.44.77.XXX (Range: 1–254, excluding 200).

Figure 4-1 Changing the IP Address

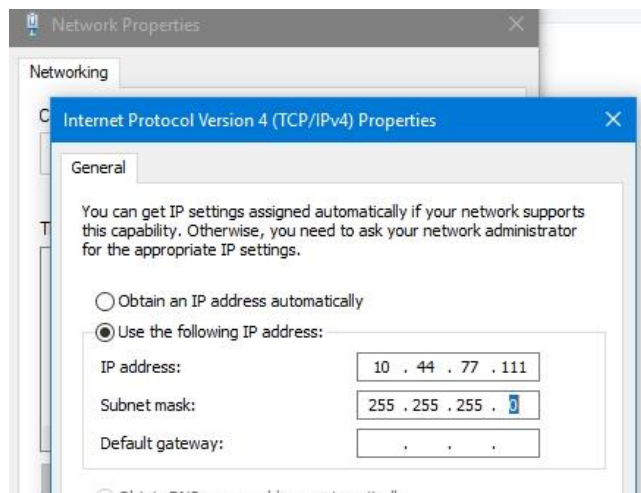

- (3) Open a browser, enter 10.44.77.200 in the address bar, and press Enter. On the login page, set a password and log in.
- (4) Perform equipment commissioning and configuration based on service requirements.

Note

For security purposes, you are advised to change the password regularly.

5 Troubleshooting

5.1 General Troubleshooting Flowchart

Note

You can determine whether each checking item in the process is normal based on the information provided in the previous chapters "Overview" and "Installing the Switch."

Figure 5-1 General Troubleshooting Flowchart

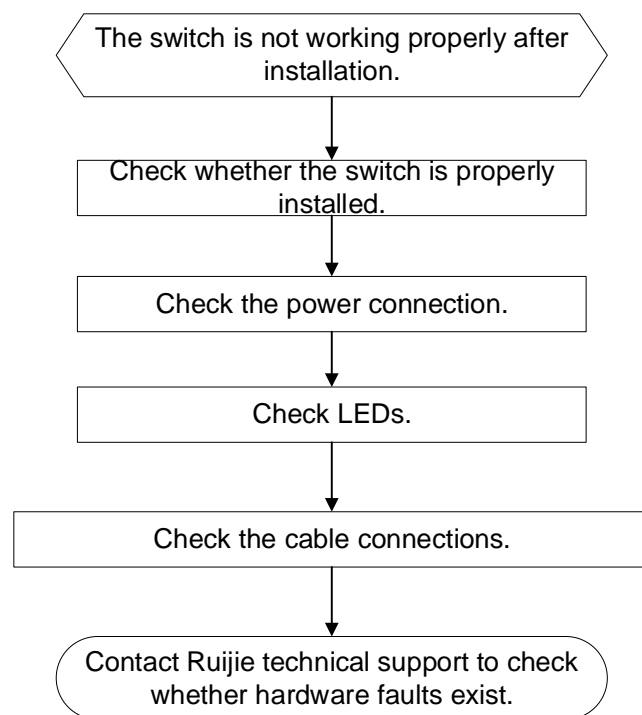

5.2 Common Faults

Table 5-1 Common Faults and Troubleshooting

Symptom	Possible Cause	Suggested Action
The system status LED is off after the switch is powered on.	No power is supplied to the switch or the power cord is loosely connected.	Check whether the power socket in the equipment room is normal and whether the power cord is loosely connected to the switch.
An RJ45 port is disconnected or a frame	The twisted pair is not connected properly.	Replace the twisted pair.

Symptom	Possible Cause	Suggested Action
sending/receiving error occurs.	The cable length exceeds 100 m (328.08 ft.).	Use an optical cable for data transmission or connect to an intermediate switch for relay.
	The port is specially configured and does not work in the same mode as that of the interconnected switch.	Check whether the port is configured to work in the same mode as that of the interconnected switch.
An optical port is not reachable.	The transmit and receive ends are connected incorrectly.	Exchange the transmit and receive ends of the optical cable.
	The types of the interconnected optical transceivers do not match.	Replace with one compatible optical transceiver.
	The optical cable type does not meet the requirements.	Replace the optical cable with a qualified one.
	The optical cable length is beyond the allowed length marked on the optical transceiver.	Use an optical cable with the required length.
	The optical cable or connector is contaminated.	Clean the connector with a lint-free cloth or a cleaning pen.
The login password cannot be retrieved.	The password is forgotten, and the equipment is not connected to the network or Ruijie Cloud.	Press and hold the Reset button to restore to factory settings.
	If the equipment is connected to Ruijie Cloud or a network, its login password is updated to the project or global management password.	If the equipment is connected to the cloud, log in using the project management password. If the equipment is connected to a network, log in using the global management password.
The Ethernet ports are transmitting and receiving frames normally, but their LEDs are off.	<p>The status of the Ethernet port LEDs is incorrectly displayed.</p> <p>The DIP switch is set to LED mode 2. As a result, the Ethernet port LEDs display the PoE status, but PoE is disabled on the ports.</p>	Set the DIP switch to LED mode 1 so that the Ethernet port LEDs display the data receiving and sending status.

6 Appendix

6.1 Connectors and Media

6.1.1 10/100/1000BASE-T Port

The 10/100/1000BASE-T port supports auto-negotiation for 10 Mbps, 100 Mbps, and 1000 Mbps connections and also supports auto MDI/MDIX Crossover.

Compliant with IEEE 802.3ab, a 1000BASE-T port connects to a 100-ohm Category 5 (CAT5) or Category 5 Enhanced (CAT5e) Unshielded Twisted Pair (UTP), or recommended Shielded Twisted Pair (STP) cable with a maximum distance of 100 m (328.08 ft.).

The 1000BASE-T port requires that all four pairs of wires be connected for data transmission. [Figure 6-1](#) shows twisted pair connections for the 1000BASE-T port.

Figure 6-1 Twisted Pair Connections for a 1000BASE-T Port

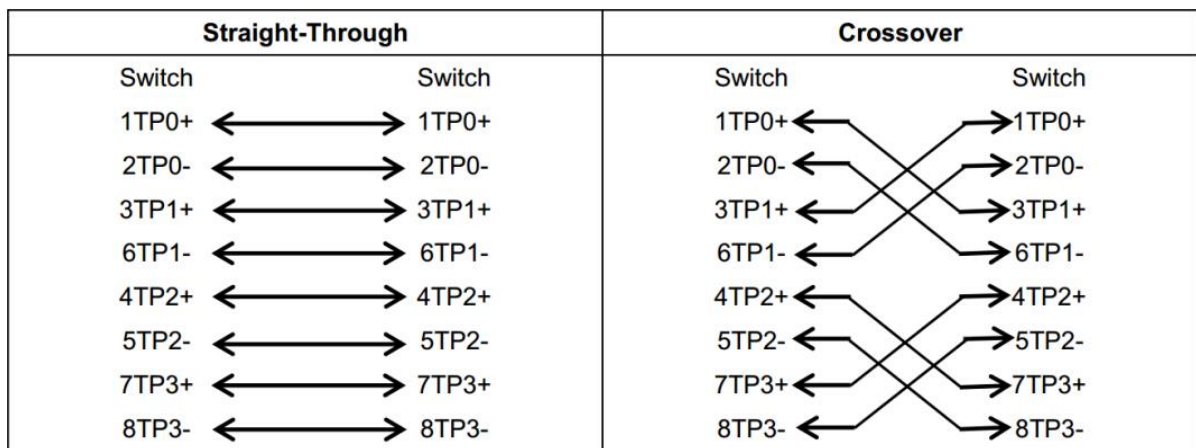

In addition to cables with the above-mentioned specifications, the 10/100BASE-T port can also be connected using 100-ohm CAT3, CAT4, and CAT5 cables at 10 Mbps or using 100-ohm CAT5 cables with a maximum distance of 100 m (328.08 ft.). The following table shows pin assignments for a 10/100BASE-T port.

Table 6-1 10/100BASE-T Pin Assignment

Pin	Socket	Plug
1	Input Receive Data+	Output Transmit Data+
2	Input Receive Data-	Output Transmit Data-
3	Output Transmit Data+	Input Receive Data+
6	Output Transmit Data-	Input Receive Data-
4, 5, 7, and 8	Not Used	Not Used

The following table shows wiring of straight-through and crossover cables for a 10/100BASE-T port.

Figure 6-2 Twisted Pair Connections for a 10/100BASE-T Port

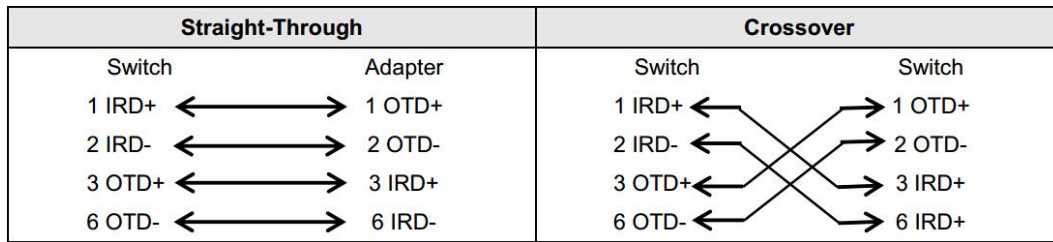

6.1.2 Optical Cable Connection

Select a single-mode fiber (SMF) or multimode fiber (MMF) for connections based on the type of the optical transceiver inserted into an optical port. [Figure 6-3](#) shows the connections.

Figure 6-3 Connecting the Optical Cables

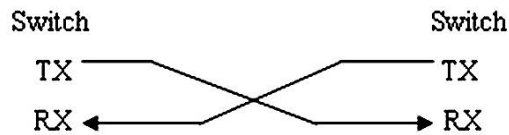

6.2 SFP Transceivers

Ruijie provides SFP transceivers (mini-GBIC) based on the port types. You can select one that suits your specific needs. In addition to the following 1GE SFP transceivers, the 1GE copper transceiver Mini-GBIC-GT is also supported. This document provides models and technical specifications of some 1GE SFP transceivers for reference. For details about the technical specifications, see *Ruijie Transceiver Installation and Reference Guide*.

Table 6-2 1GE Mini-GBIC (SFP) Models and Technical Specifications

Model	Wavelength (nm)	Fiber Type	DDM Supported (Yes/No)	Transmit Power (dBm)		Receive Power (dBm)	
				Min	Max	Min	Max
MINI-GBIC-SX-MM850	850	MMF	Yes	-9	-3	-20	-3
MINI-GBIC-LX-SM1310	1310	SMF	Yes	-9	-3	-26	0
GE-SFP-LH40-SM1310-BIDI	1310TX/1550RX	SMF	Yes	-3	3	-25	0
GE-SFP-LH40-SM1550-BIDI	1550TX/1310RX	SMF	Yes	-3	3	-25	0

GE-SFP-LX20-SM1310-BIDI	1310TX/1550RX	SMF	Yes	-8	-3	-23	-3
GE-SFP-LX20-SM1550-BIDI	1550TX/1310RX	SMF	Yes	-8	-3	-23	-3
MINI-GBIC-LH40-SM1310	1310	SMF	Yes	-5	0	-25	-3
MINI-GBIC-ZX80-SM1550	1550	SMF	Yes	-3	3	-26	-3
GE-SFP-LX03-SM1310-BIDI-I	1310TX/1550RX	SMF	Yes	-9	-3	-22	-3
GE-SFP-LX03-SM1550-BIDI-I	1550TX/1310RX	SMF	Yes	-9	-3	-22	-3
SFP-MM850	850	MMF	Yes	-9.5	-3	-17	-3
SFP-SM1310	1310	SMF	Yes	-9	-3	-20	-3

Table 6-3 1GE SFP Copper Transceivers

Standard	1000BASE-T SFP Module	DDM Supported (Yes/No)
1000BASE-T	Mini-GBIC-GT	No

Table 6-4 Cabling Specifications of SFP Transceivers

SFP Transceiver Model	Port Type	Fiber Type	Core Size (µm)	Max Cabling Distance
SFP-SM1310	LC	SMF	9/125	10 km (6.21 miles)
MINI-GBIC-LX-SM1310	LC	SMF	9/125	10 km (6.21 miles)
GE-SFP-LH40-SM1310-BIDI	LC	SMF	9/125	40 km (24.85 miles)
GE-SFP-LH40-SM1550-BIDI	LC	SMF	9/125	40 km (24.85 miles)
GE-SFP-LX20-SM1310-BIDI	LC	SMF	9/125	20 km (12.43 miles)
GE-SFP-LX20-SM1550-BIDI	LC	SMF	9/125	20 km (12.43 miles)
MINI-GBIC-LH40-SM1310	LC	SMF	9/125	40 km (24.85 miles)

SFP Transceiver Model	Port Type	Fiber Type	Core Size (µm)	Max Cabling Distance
				miles)
MINI-GBIC-ZX80-SM1550	LC	SMF	9/125	80 km (49.71 miles)
GE-SFP-LX03-SM1310-BIDI-I	LC	SMF	9/125	3 km (1.86 miles)
GE-SFP-LX03-SM1550-BIDI-I	LC	SMF	9/125	3 km (1.86 miles)
MINI-GBIC-SX-MM850	LC	MMF	62.5/125	275 m (902.23 ft.)
			50/125	550 m (1,804.46 ft.)
SFP-MM850	LC	MMF	62.5/125	275 m (902.23 ft.)
			50/125	550 m (1,804.46 ft.)
Mini-GBIC-GT	RJ45 Ethernet cable	CAT5 or better UTP or STP cable		100 m (328.08 ft.)

⚠ Caution

- For optical transceivers with a cabling distance of no less than 40 km (24.85 miles), install an optical attenuator to avoid overload on an optical receiver when using short-distance SMFs.
- An optical transceiver is a laser transmitter. Do not look into the light source to prevent it from burning your eyes.
- To keep the optical transceiver clean, make sure that the unused ports remain capped.

Table 6-5 BIDI Optical Transceiver Pairing

Rate/Distance	Pairing Model
1000 Mbps/3 km (1.86 miles)	<ul style="list-style-type: none"> ● GE-SFP-LX03-SM1310-BIDI-I ● GE-SFP-LX03-SM1550-BIDI-I
1000 Mbps/20 km (12.43 miles)	<ul style="list-style-type: none"> ● GE-SFP-LX20-SM1310-BIDI ● GE-SFP-LX20-SM1550-BIDI
1000 Mbps/40 km (24.85 miles)	<ul style="list-style-type: none"> ● GE-SFP-LH40-SM1310-BIDI ● GE-SFP-LH40-SM1550-BIDI

⚠ Caution

BIDI optical transceivers must be used in pairs. For example, if GE-SFP-LX20-SM1310-BIDI is used at one end, GE-SFP-LX20-SM1550-BIDI must be used at the other end.

6.3 Lightning Protection

6.3.1 Installing the AC Power Arrester (Power Strip with Surge Protection)

When an alternating current (AC) power cord is introduced from outdoors and directly connected to the AC power port of the switch, the power port must be connected to an external power arrester to safeguard the switch against lightning strikes. The power arrester can be fixed on the rack, workbench, or wall in the equipment room by using cable ties and screws. AC power enters the power arrester before entering the switch.

Figure 6-4 Power Arrester

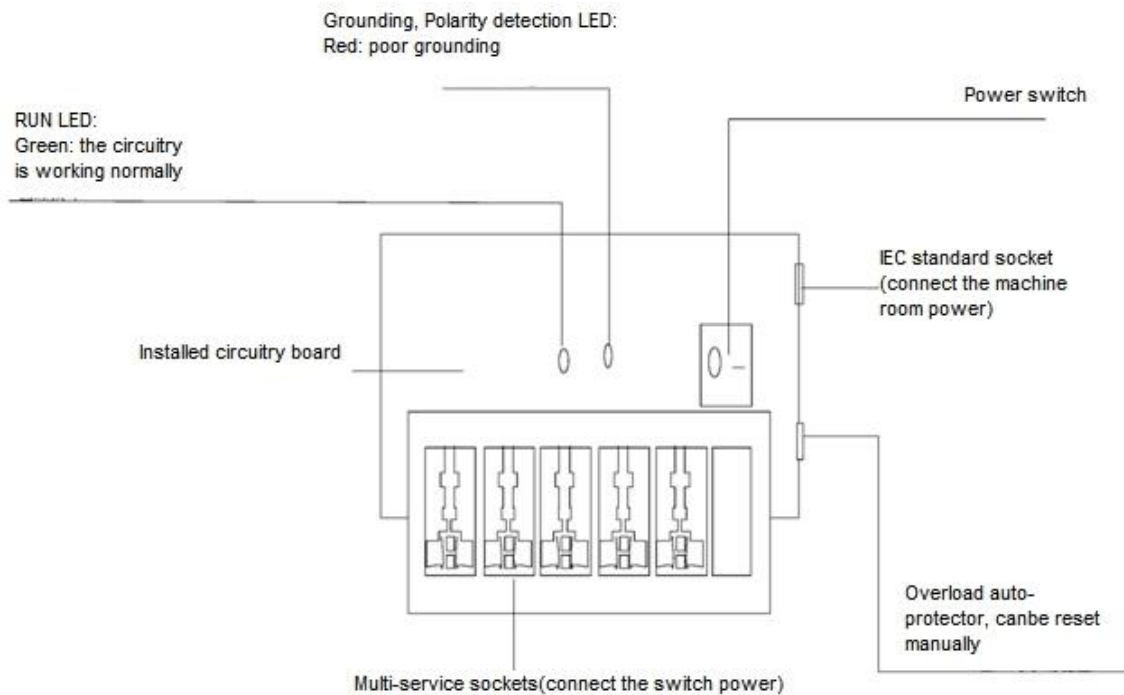

⚠ Caution

The power arrester is not delivered with the equipment. Please purchase it based on actual requirements.

Precautions during the installation:

- Make sure that the PE terminal of the power arrester is well grounded.
- After the AC power plug of the switch is connected to the socket of the power arrester, the lightning protection function is implemented only if the running status LED is green and the alarm LED is off.
- If the alarm LED on the power arrester is red, check whether it is caused by a poor grounding connection or

by the reversed connection of the neutral and live wires. The detection method is as follows: Use a multimeter to measure the polarity of the power arrester when the alarm LED is red. If the neutral wire is on the left and the live wire is on the right (facing the socket), the PE terminal of the power arrester is not grounded. If not, the polarity of the power arrester should be reversed. In this case, open the power arrester and reverse its polarity. If the alarm LED is still red, the PE terminal of the power arrester is not grounded.

6.3.2 Installing the Ethernet Port Arrester

Please connect an Ethernet port arrester to the switch to prevent the damage by lightning strikes before connecting an outdoor Ethernet cable to the switch.

- Tools: Phillips screwdriver or flat-blade screwdriver, multimeter, and diagonal pliers
- Installation steps
 - a Tear one side of the protective paper for the double-sided adhesive tape and paste the tape to the enclosure of the Ethernet port arrester. Tear the other side of the protective paper for the double-sided adhesive tape and paste the Ethernet port arrester to the switch enclosure. The paste position for the Ethernet port arrester should be as close to the grounding lug of the switch as possible.
 - b Based on the distance between the grounding lug of the switch and the Ethernet port arrester, cut the grounding cable of the Ethernet port arrester and firmly tighten the grounding cable to the grounding lug of the switch.
 - c Use a multimeter to check whether the grounding cable for the arrester is in good contact with the grounding lug and the enclosure of the switch.
 - d Connect the Ethernet port arrester by using an adapter cable (note that the external Ethernet cable is connected to the IN end, while the adapter cable connected to the switch is connected to the OUT end) and check whether the module LED is normal.
 - e Use a nylon cable tie to bind the cables.

Figure 6-5 Installing an Ethernet Port Arrester

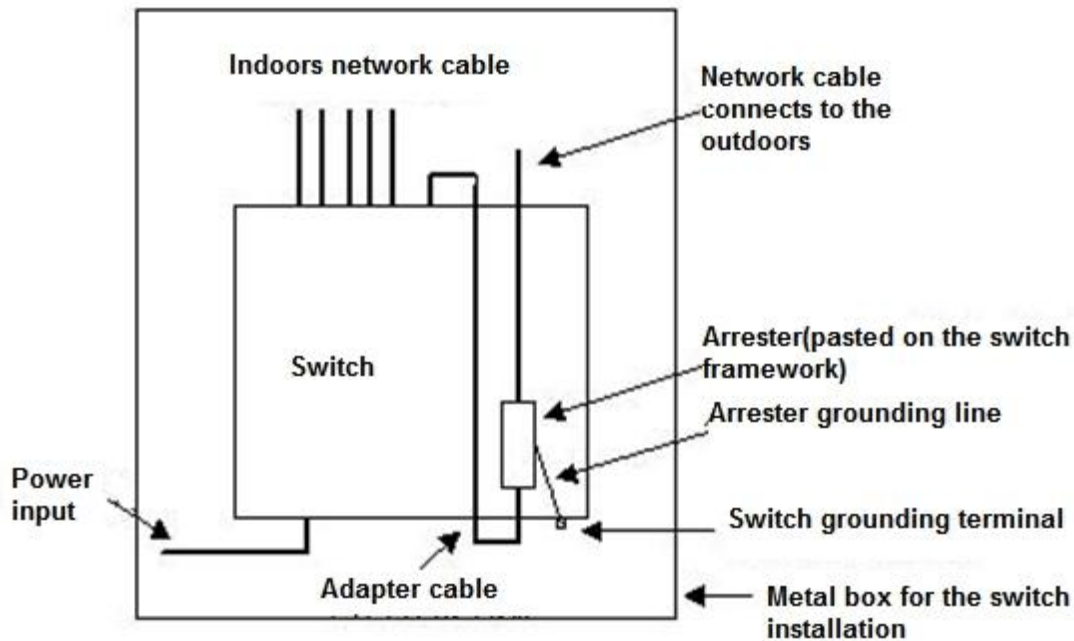

⚠ Caution

- The Ethernet port arrester is only for a 10 Mbps, 100 Mbps, or 1000 Mbps RJ45 port.
- The Ethernet port arrester is not delivered with the equipment. Please purchase it based on actual requirements. The user manual for Ethernet port arresters contains technical parameters and maintenance and installation instructions. Carefully read this manual during installation.

Pay attention to the following situations during the actual installation to avoid influencing the performance of an Ethernet port arrester:

- The arrester is incorrectly connected to the cables. Connect the external Ethernet cable to the IN end and connect the Ethernet port of the switch to the OUT end.
- The Ethernet port arrester is incorrectly grounded. The grounding cable of the arrester should be as short as possible to ensure that it is in good contact with the grounding lug of the switch. Use a multimeter to confirm the contact condition after grounding.
- Not all Ethernet ports are installed with Ethernet port arresters. If outdoor Ethernet cables connect the switch ports to the peer equipment, Ethernet port arresters need to be installed on all the ports for the purpose of lightning protection.

6.4 Recommended Cabling

When the switch is installed in a standard 19-inch cabinet, secure the cables around the cable management brackets. Top cabling or bottom cabling is adopted according to the actual situation in the equipment room. All adapted connectors should be placed at the bottom of the rack in an orderly manner instead of outside the rack that is easy to touch. Power cords are routed beside the rack. Top cabling or bottom cabling is adopted according

to the actual situation in the equipment room, such as the positions of the DC power distribution box, AC socket, or lightning protection box.

6.4.1 Requirement for the Minimum Bend Radius of Cables

- The bend radius of a fixed power cord, Ethernet cable, and flat cable should be over five times greater than their respective external diameters. The bend radius of these cables that are often bent or plugged should be over seven times greater than their respective external diameters.
- The bend radius of a fixed common coaxial cable should be over seven times greater than its external diameter. The bend radius of these cables that are often bent or plugged should be over 10 times greater than their respective external diameters.
- The minimum bend radius of a high-speed cable, such as an SFP+ cable, should be 5 times the overall diameter of the cable. If the cable is constantly bent, plugged or unplugged, the bend radius should be 10 times the overall diameter.
- The minimum bend radius of optical cables should meet the following requirements.
 - The diameter of the optical cable tray should be no less than 25 times greater than that of the optical cable.
 - When an optical cable is moved, its bend radius should be no less than 20 times greater than its diameter.
 - During cabling of an optical cable, its bend radius should be no less than 10 times greater than its diameter.

6.4.2 Precautions for Cable Bundling

- Before cables are bundled, mark labels and stick the labels to cables wherever appropriate.
- Cables should be neatly and properly bundled in the rack without twisting or bending, as shown in [Figure 6-6](#).

Figure 6-6 Bundling Cables (1)

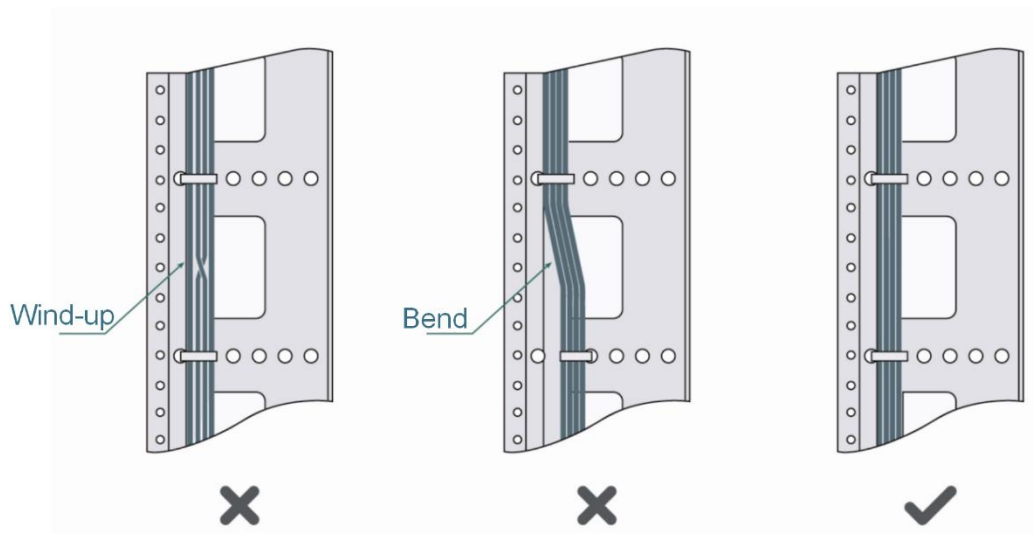

- Cables of different types (such as power cords, signal cables, and grounding wires) should be separated in cabling and bundling. Mixed bundling is not allowed. When they are close to each other, you are advised to

adopt crossover cabling. In the case of parallel cabling, maintain a minimum distance of 30 mm (1.18 in.) between power cords and signal cables.

- The cable management brackets and cabling troughs inside and outside the rack should be smooth without sharp corners.
- The metal holes traversed by cables should have a smooth and fully rounded surface or an insulated lining.
- Use cable ties to bundle cables properly. Please do not connect two or more cable ties to bundle cables.
- After bundling up cables with cable ties, cut off the remaining part. The cut should be smooth and trim without sharp corners, as shown in [Figure 6-7](#).

Figure 6-7 Bundling Cables (2)

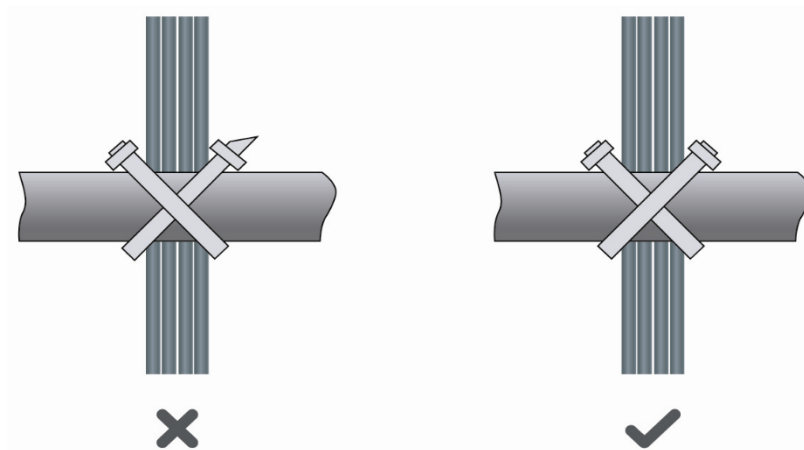

- When cables need to be bent, bundle them first but do not tie cables within the bend. Otherwise, stress may be generated on the cables and cause the wires inside to break, as shown in [Figure 6-8](#).

Figure 6-8 Bundling Cables (3)

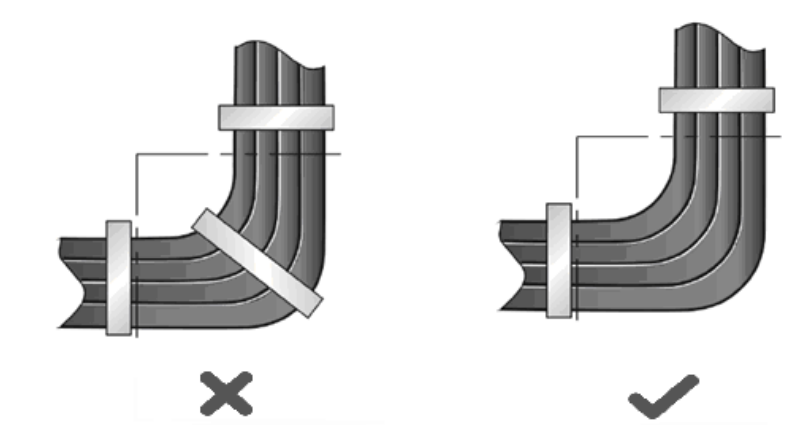

- Cables not to be assembled or the remaining parts of cables should be folded and placed in a proper position of the rack or cable management trough. The proper position refers to a position that does not affect the equipment running or damage the equipment or cables.
- Power cords must not be bundled on the guide rails of moving parts.
- The power cords connecting moving parts such as door grounding wires should be reserved with some

excess after being assembled to avoid suffering tension or stress. When a moving part reaches the installation position, the remaining cable part should not touch heat sources, sharp corners, or sharp edges. If heat sources must be touched, high-temperature cables should be used.

- When using screw threads to secure a cable lug, ensure that the bolt or screw is properly tightened and take measures to prevent it from loosening, as shown in [Figure 6-9](#).

Figure 6-9 Fastening Cables

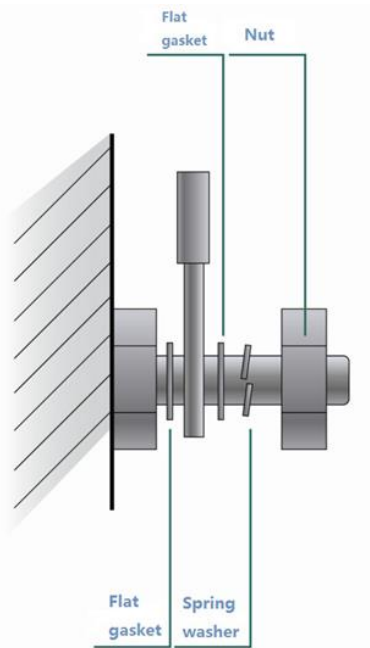

- Hard power cords should be secured near the cable termination area to prevent stress on the cable termination area and cables.
- Do not use tapping screws to secure cable lugs.
- Power cords of the same type and in the same cabling direction should be bundled up into cable bunches, with cables in cable bunches clean and straight.
- Bundle cables by using cable ties according to the following table.

Cable Bunch Diameter	Bundling Spacing
10 mm (0.39 in.)	80–150 mm (3.15–5.91 in.)
10–30 mm (0.39–1.18 in.)	150–200 mm (5.91–7.87 in.)
30 mm (1.18 in.)	200–300 mm (7.87–11.81 in.)

- Do not tie cables or bundles in a knot.
- For wiring terminal blocks (such as circuit breakers) with cord end terminals, the metal part of the cord end terminal should not be exposed outside the terminal block when assembled.

6.5 Site Selection

- The equipment room should be at least 5 km (3.11 miles) away from heavy pollution sources, such as smelters, coal mines, and thermal power plants. The equipment room should be at least 3.7 km (2.30 miles) away from medium pollution sources, such as the chemical factory, rubber factory, and electroplating factory. The equipment room should be at least 2 km (1.24 miles) away from light pollution sources, such as the food factory and leather plant. If the pollution source is unavoidable, the equipment room should be located on the windward side of the pollution source perennially with advanced protection.
- The equipment room should be at least 3.7 km (2.30 miles) away from the sea or salt lake. Otherwise, the equipment room must be sealed, with an air conditioner installed for temperature control. Saline soil cannot be used for construction. Otherwise, you should select equipment with advanced protection against severe environments.
- Do not build the equipment room in the proximity of livestock farms. Otherwise, the equipment room should be located on the windward side of the pollution source perennially. The previous livestock house or fertilizer warehouse cannot be used as the equipment room.
- The equipment room should be firm enough to withstand severe weather conditions such as windstorms, heavy rain, and dense dust. If the dust is unavoidable, keep the door and window away from the pollution source.
- The equipment falls into Class A. Therefore, the equipment room should be located away from the residential area. Otherwise, the equipment room should meet construction specifications to avoid noise and radio interference.
- Make sure the air vent of the equipment room is away from the sewage pipe, septic tank, and sewage treatment tank. Keep the equipment room under positive pressure to prevent corrosive gas from entering the equipment room to corrode components and circuit boards.
- Keep the equipment room away from industrial boilers and heating boilers.
- The equipment room should be on the second floor or higher. Otherwise, the equipment room floor should be 600 mm (23.62 in.) higher than the highest flood level ever recorded.
- Make sure no cracks or holes exist in the wall and floor. If there are cable entries in the wall or window, take proper sealing measures. Ensure that the wall is flat, wear-resistant, and dust-free, meeting standards for flame resistance, soundproofing, heat absorption, dust reduction, and electromagnetic shielding.
- Keep the door and the window closed to make the equipment room sealed.
- You are advised to use the steel door for soundproofing.
- Do not use sulfur-containing materials.
- Keep the air conditioner from blowing wind straight toward the equipment or blowing water drops from the window or air vent toward the equipment.